

# MAG-AD9 INSTALL INSTRUCTIONS

**1**  **WARNING:** Before working on any firearm be certain it is unloaded, clear of any ammunition, and that all ammunition is stored away from your work area. **This product requires a caliber specific barrel and a glock cut bolt.**

Included:  
2x Hex Wrench  
SIZE: 3/32 & 5/64



FOR A DETAILED INSTRUCTION VIDEO PLEASE VISIT:  
**www.getstern.com**

**2** 

If you received your MAG-AD9 from the factory, you may skip to step 4.

Please loosen the indicated screw. (Note, this gib adjusting screw does not back out all the way. **DON'T TRY IT!**)

**3** 

Using the 5/64 Hex wrench back out the two nylon tip set screws until they are flush with the top.

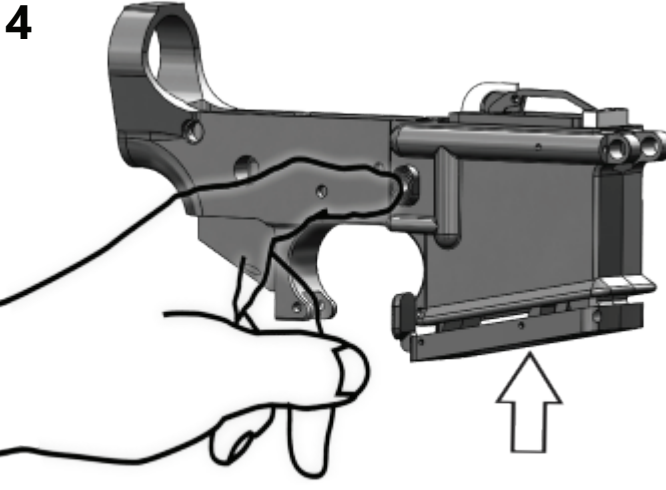
**4** 

Depress the mag release button on your lower receiver and slide your MAG-AD9 in until it clicks into place. This is similar to the way you would load a magazine into a lower receiver.

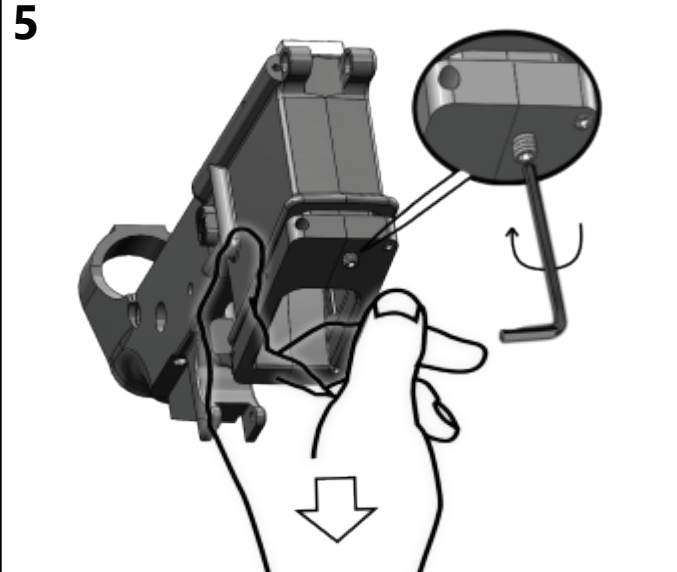
**5** 

While pulling the MAG-AD9 outward and keeping it level, take your 3/32 Hex wrench and tighten the gib adjusting screw.

**6** 

Using the 5/64 Hex wrench, tighten the two nylon tip set screws until they touch the bottom of the lower. **(DO NOT over tighten.)**